

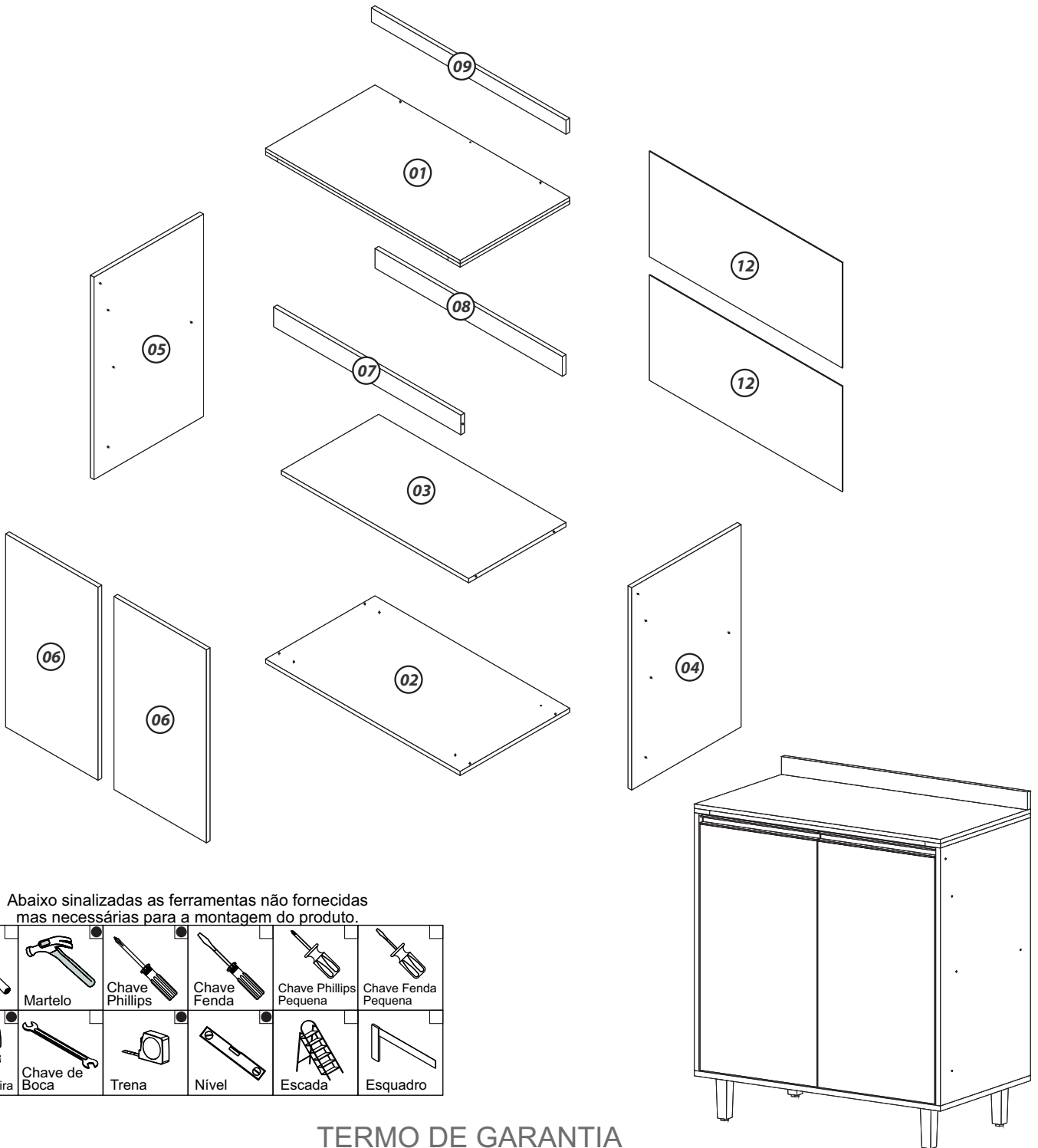

COZINHA TURQUESA BALCÃO 0,80

ESQUEMA DE MONTAGEM

Para assistência técnica, entre em contato com a loja onde adquiriu este móvel.



TERMO DE GARANTIA

DISPOSIÇÕES

O projeto, instalação e a montagem na residência do consumidor não é responsabilidade da Vitamov. A montagem deve seguir corretamente as instruções que se encontram dentro da embalagem de cada módulo.

A Vitamov se reserva o direito de efetuar modificações de caráter técnico em seus produtos, sem aviso prévio.

EXCLUSÃO DA GARANTIA

O presente termo exclui de sua garantia:

- danos causados em consequência de acidentes, mau uso, manuseio ou deslocamento incorreto dos produtos;
- danos causados por montagem inadequada;
- danos em decorrência de agentes externos (inundações, incêndio, etc);
- defeitos oriundos de umidade excessiva

A fixação dos armários de forma segura e garantida depende da qualidade da parede na qual os mesmos serão instalados. A Vitamov não se responsabiliza por danos causados por instalações dos armários em paredes inadequadas.

ACESSÓRIOS

A - 02x

B - 03x

C - 10x

D - 04x

E - 04x

F - 40x

G - 04x

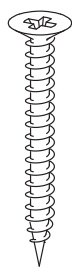

Paraf.
5,5 x 75 CH

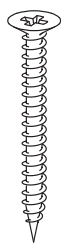

Paraf.
5,0 x 60 CH

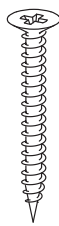

Paraf.
5,0 x 45 CH

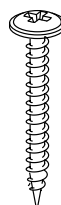

Paraf.
4,5 x 45 FL

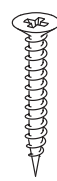

Paraf.
3,5 x 25 CH

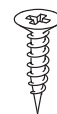

Paraf.
3,5 x 14 CH



Paraf.
M4 x 20 CH

H - 04x

I - 02x

J - 02x

K - 02x

L - 04x

M - 04x



Porca M4

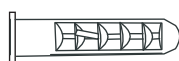

Bucha p/ Parede 8mm

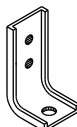

Cantoneira L Parede

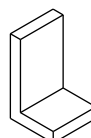

Capa Plástica



Dobradiça 35mm

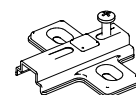

Calço Dobr.

N - 02x

O - 04x

P - 06x

Q - 24x

R - 04x

S - 02x

T - 10x

U - 01x

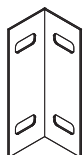

Canton. 4F



Canton.
18x18x14

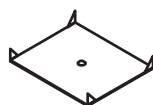

Garra p/ Fundo



Prego 8 x 11



Pé Cromado

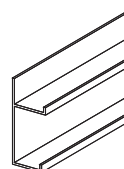

Puxador



Tapa F.
Adesivo 12mm



Batente
de Porta

IDENTIFICAÇÃO DAS PEÇAS

ORD.	CÓDIGO	DESCRIÇÃO	DIM. (mm)	ESP. (mm)	QTDE
01	2747	Tampo	800 x 450	24	1
02	2745	Base	800 x 450	15	1
03	2748	Prateleira	770 x 400	15	1
04	2750	Lateral Direita	720 x 450	15	1
05	2751	Lateral Esquerda	720 x 450	15	1
06	2757	Porta	687 x 380	15	2
07	2752	Batente de Porta	770 x 70	15	1
08	2746	Trava	770 x 70	15	1
09	2749	Régua	800 x 50	15	1
12	2756	Fundo	793 x 375	03	2

1

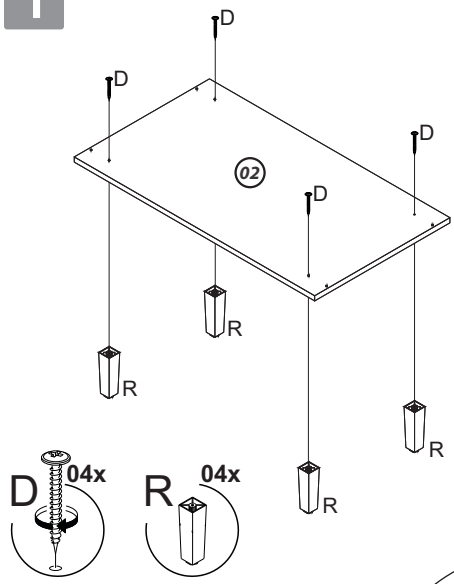

2

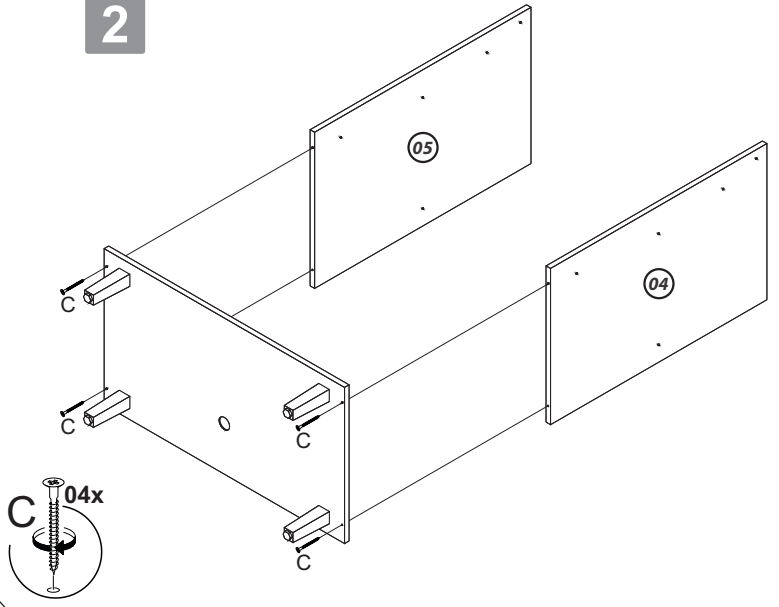

3

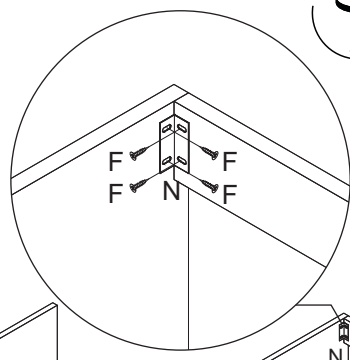
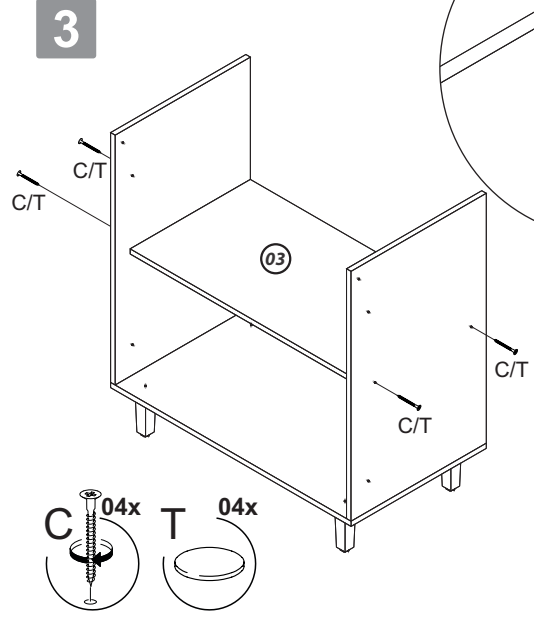

4

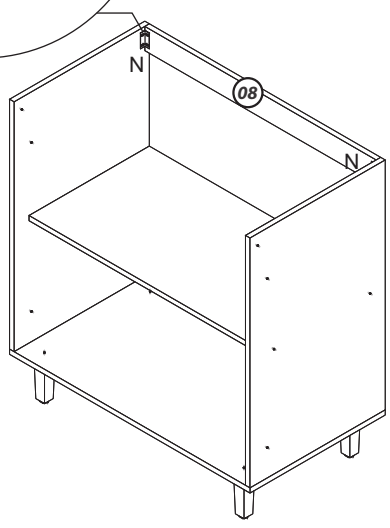

5

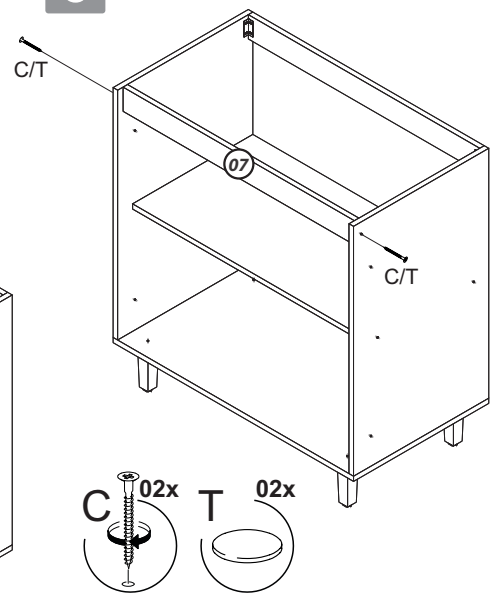

6

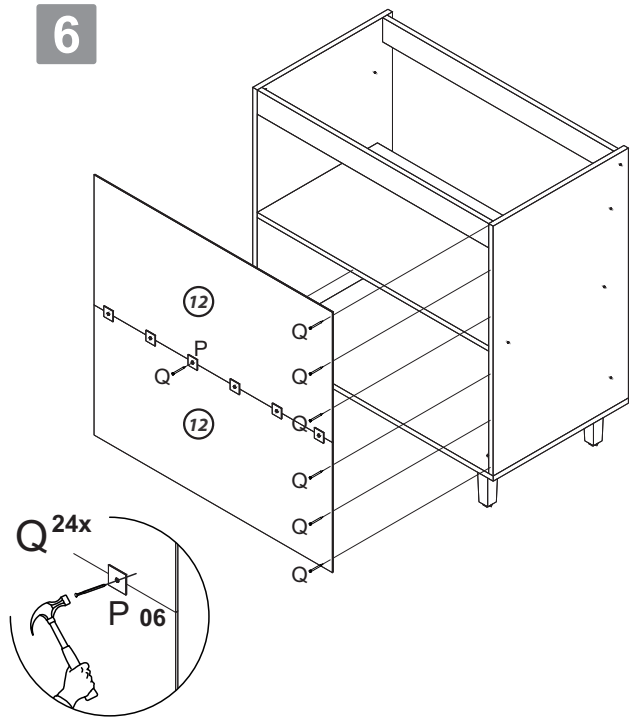

7

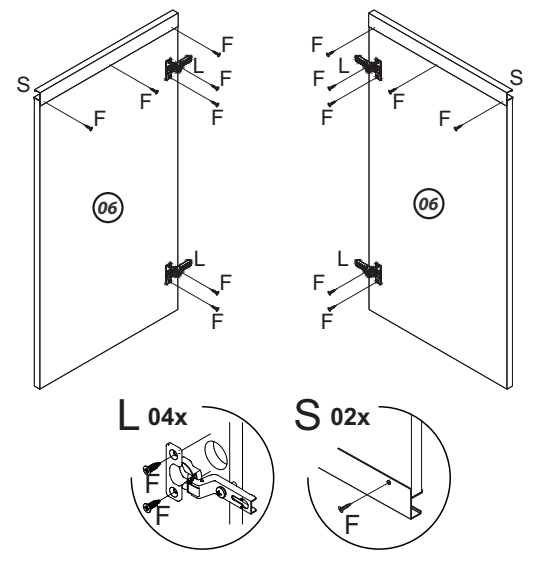

8 Utilize os parafusos (F) para fixar as cantoneiras (J) nos cantos internos superiores.

Deve ser deixada uma folga em relação à lateral para encaixe da capa do suporte.

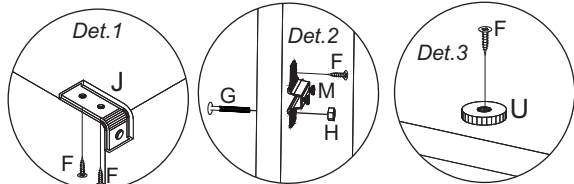
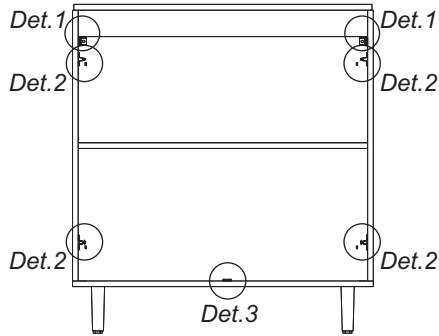

Utilizar os Parafusos (G) e as Porcas (H) nos furos dos Calços (M).



A empresa não se responsabilizará por acidentes decorrentes da não observância dos passos descritos e nem pela fragilidade da parede.

11 Com uma broca Ø8mm (não fornecida) fazer os furos na parede e encaixar as buchas plásticas (I).

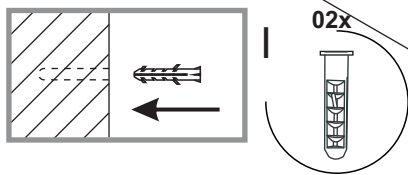
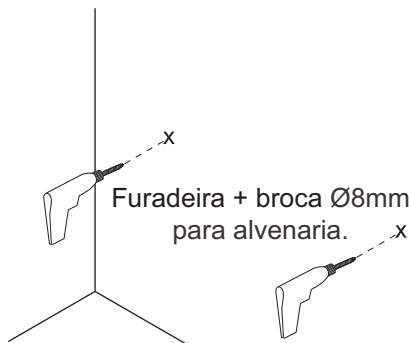

14

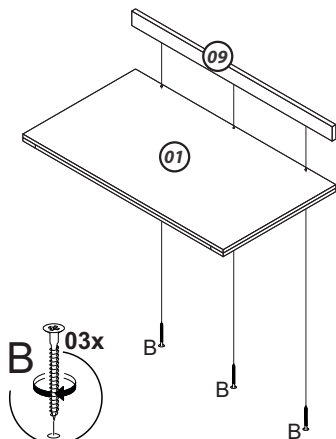

9 Com o auxílio de uma furadeira + broca Ø8mm (não fornecidas), fazer a furação dos fundos.

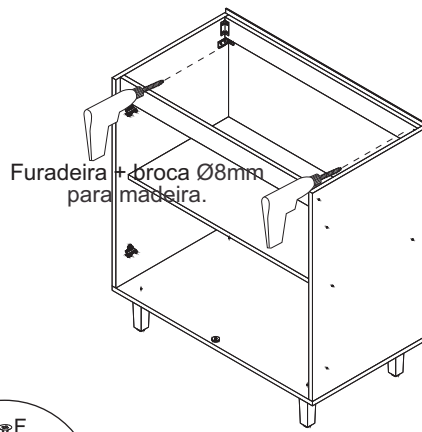

10 Posicionar e nivelar o balcão no local de uso e marcar a parede através dos furos.

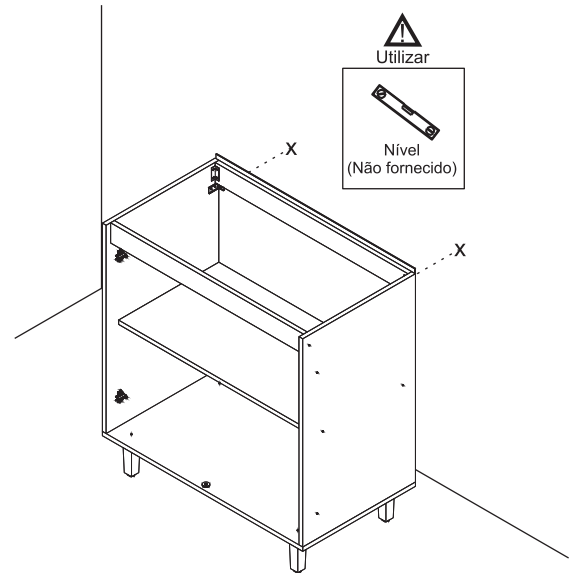

12 Utilizar os parafusos (A) para fixar o balcão na parede.

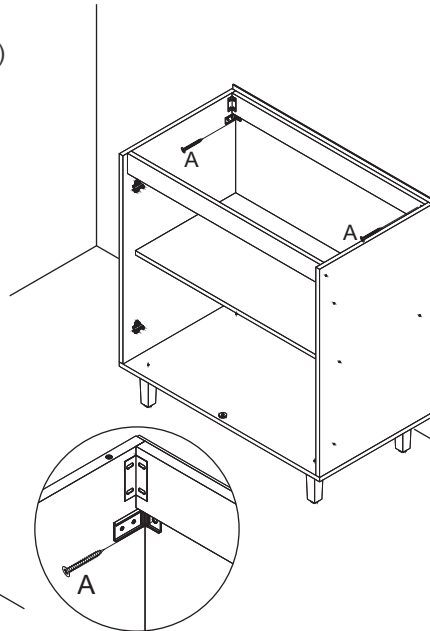

13 Caso deseje fazer a união entre módulos utilize os parafusos (E). Utilizar as capas para suporte (K) para acabamento.

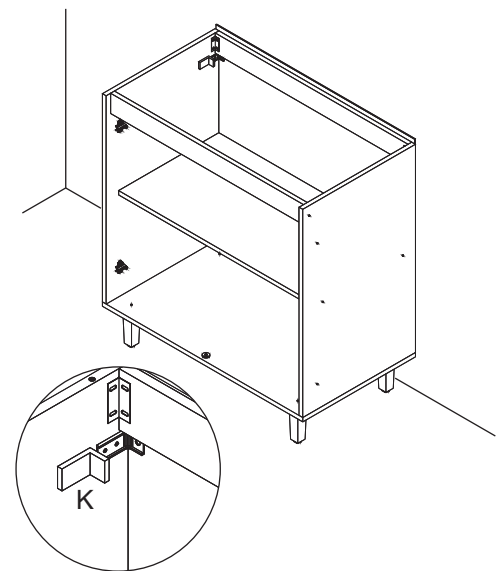

15

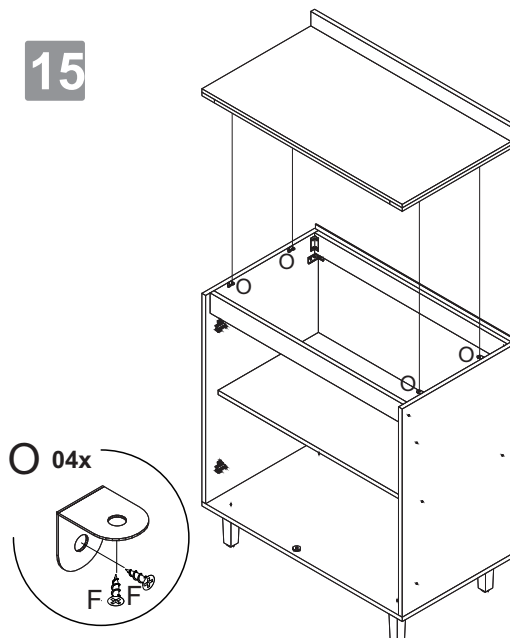

16

